

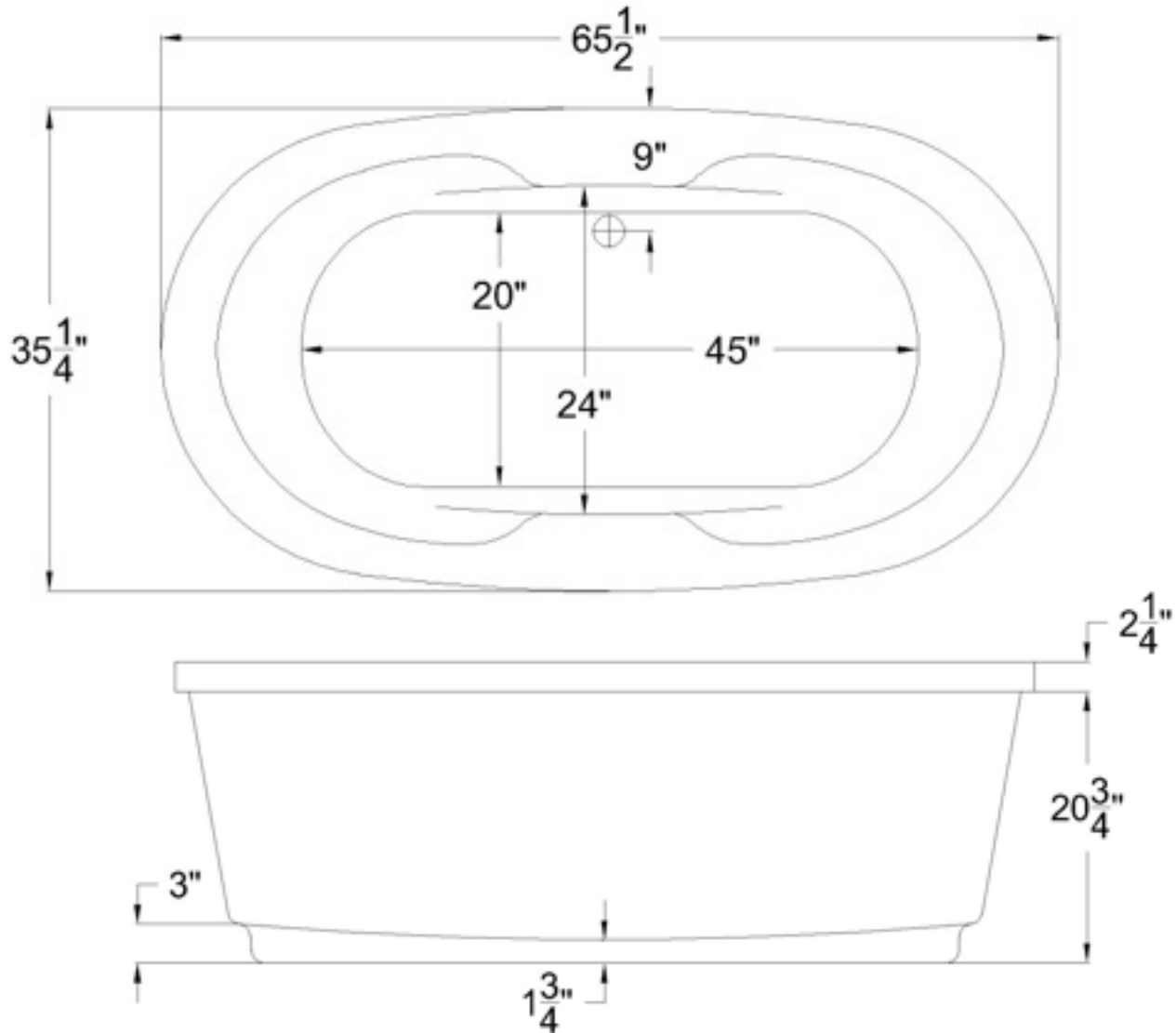

CT3666CDP (Pedestal Tub)



Standard Equipment Specifications:

- Maximum Water Depth 14"
- Maximum Water Capacity 60 Gal. (Without Bather)
- 20 Year Limited Warranty
- Measurements Vary +/- 1/4"

Optional Equipment Specifications:

- Tranquility Electric In-Line Heater 1.5KW (Requires Own 120V/15A GFCI)
- Thermal Air Massage 108 Air Inlet 1HP Air Blower (Requires Own 120V/15A GFCI)